



AIR CONDITIONING



REFRIGERATION



HEATING



hi-flow 0.5L

CONDENSATE REMOVAL PUMP



This compact yet powerful pump has the smallest footprint of all our centrifugal tank pumps. Offering extra placement flexibility when space is limited.



300L/h max. flow



3.2m max. rec. head (flow rate 50L/h)

KEY FEATURES

- Plug & play
- Non return valve
- Wall or floor mounted

SUITABILITY

- Up to 240kW / 818,000Btu/h
- Ducted units; Floor standing & Chassis units; Cassette units; Refrigerated units / cold store

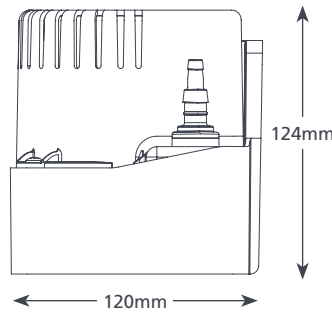
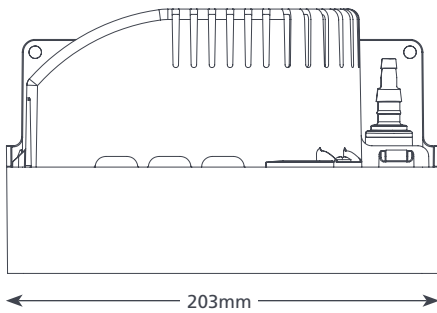

HI-FLOW 0.5L SPECIFICATIONS

Max. flow	300L/h @ 0 head
Max. rec. head	3.2m
Tank capacity	0.5L
Sound level@1m	51dB(A)
Power supply	230 VAC, 0.45A, 50Hz
Rated	Non continuous
Class	I appliance
Max. unit output	240kW / 818,000Btu/h
Max. water temp	40°C / 104°F
Inlet/outlet	x2 27mm in, 6-10mm out
IP Protection	IP20
Safety switch	3.0A Normally closed
Thermal protection	✓
Fully potted	n/a
Self priming	n/a

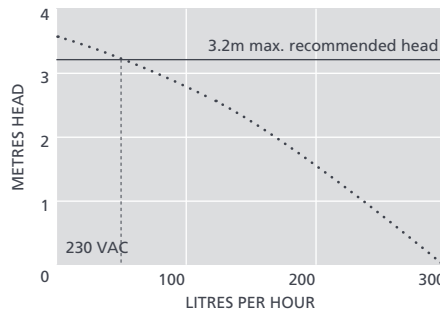

SUGGESTED XTRA ACCESSORIES

Description	Part No.
Tank pump connector 16mm-21mm	FP2011
Tube To Soil Stack Adaptor	FP2038
Vinyl Tube Braided 1/4" (6mm)	AX5110



For more installation accessories take a look at our Aspen Xtra range

HI-FLOW 0.5L OPTIONS

Hi-flow 0.5L	FP1194/2
--------------	----------

IN THE BOX

Hi-flow 0.5L pump • 2m Plug & play power cable • Fixing kit • Install manual

Download manual at aspenspumps.com

Information correct at time of going to press.